

PROGRAM TERMINAL

PRODUCT NUMBER 3030

Indicator



- > 10 application programs
- > Stainless steel housing 1.4301, Protection Class IP 67
- > With integrated power supply 100-240V, 50/60Hz, 400mA
- > Indicator with dot matrix display 240 x 128 pixels
- > Adjustable backlighting
- > Alphanumeric input keypad
- > Weighing ranges: 0.1 to 120,000kg
- > 3 analogue/digital measuring points connectable internally
- > EU Class III – approvable resolution for approx. 10,000e
- > Barcode management

Features

The approvable Program Terminal 3030 is the well conceived solution for applications in incoming goods, and in production, store and shipping departments. Precise, rapid metrology for modern weighing solutions in the food industry, pharmaceuticals and chemical industry as well as in the electrical and mechanical engineering industries.

Functions

Every weighing operation has its particularities. The 10 different application programs on the Soehnle Program Terminal 3030 offer you a wide range of solutions for the following weighing operations:

- › Weighing and taring
- › Totalising and batching
- › Counting
- › Checking
- › Classifying
- › Recipes
- › Weight conversion
- › Vehicle weighing
- › Interface programming
- › Percentage weighing

Please note the folding page containing descriptions of the programs. Special programs are available on request.

Housing

- › Compact housing made of stainless steel 1.4301, Protection Class IP 67 suitable for aggressive environments
- › Available for installation in bench, wall or cabinet or on a stand
- › Integrated power supply, cable routed through sealed cable gland
- › Pressure equalisation by gas-permeable membrane

Possible connection setups

- › 3 analogue/digital measuring points connectable
- › Total of up to 30 measuring points
- › Approvable resolution up to 10,000e/3 x 3000e when fitted with suitable load cells
- › Barcode scanner connectable to RS 232 interface
- › PC keyboard
- › Additional indicator

Ask your specialist dealer or one of our employees.

Interfaces

- › Standard equipment with one RS 232 data interface
- › Optional: other interfaces are available, e.g. RS 422, RS 485, 20mA CL
- › Various Fieldbus connections such as Profibus DP, Interbus S, Modbus, Canbus and Ethernet connectivity options
- › Connection to printer, control and warehouse management system are possible without any problems.

Approvable alibi memory via data memory

- › Multi-Media-Card (MMC) with 32MB memory capacity for 2 million entries in the approvable alibi memory (optional)
- › Fixed value memory for max. 400 entries valid for all programs, e.g. for tare memory, reference weight memory, etc.
- › Database function for organisation data

Dimensions (mm)

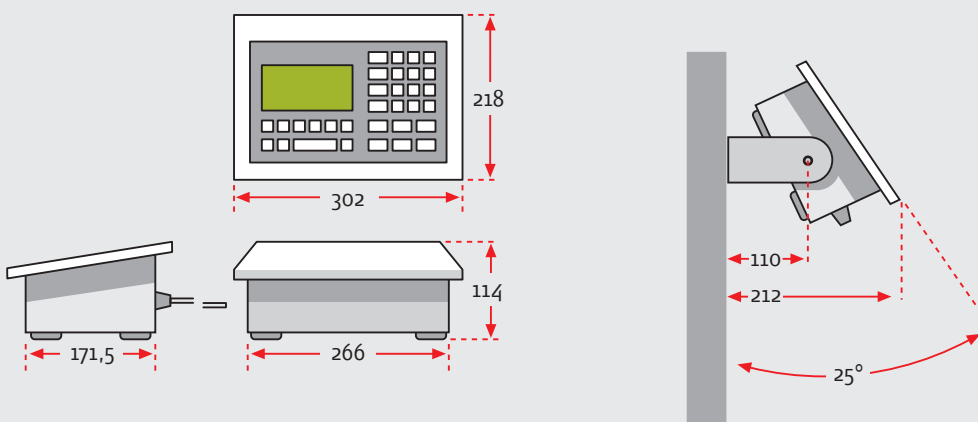

Operation, keypad and indicator

Accessories

There is a wide range of accessories for the Program Terminal 3030, e.g.:

- › Tape and label printer
- › Other digital/analogue measuring points
- › Approvable break point in the measuring cable
- › I/O module, relay box, series of indicator lamps
- › Anybus board, e.g. Profibus
- › DC power supply
- › Barcode scanner
- › Alibi memory
- › Software for fixed value input via PC
- › Wall or stand holder
- › External PC keyboard

Print

Besides the standard Tape Printer 2795.11.001 and the Label Printer 2795.12.001, all EU approved printers are connectable to the RS 232 serial interface.

15 program-specific standard print templates and data processing records are preset at the factory. User-defined print templates on request.

Mechanical design

- › A scale basically consists of a Program Terminal 3030 and one or more weighing machines connected by cable to one or more load cells.
- › 1 to 3 measuring points are permanently connected to the appliance and optionally disconnectable by means of an approvable break point in the measuring cable.
- › Approvable break point: an ID chip is integrated in the Program Terminal to identify every weighing machine.

Indicator

- › Dot matrix display (240 x 128 pixels), backlit and settable
- › The display shows a number of different situation-dependent views divided into display panes, e.g. additional indicator, symbol bar, information pane, display pane and function bar.

Keypad

- › Membrane keyboard with large keys and pressure point
- › Smooth surface, easy to clean membrane keyboard meets all requirements regarding ergonomics, hygiene and service life.
- › Total of 32 keys, of which 6 function keys, 4 keys for organisation data, alphanumeric key to input manual tare weights, piece weights and accompanying texts using numeric keys
- › Application-specific function input via function keys
- › Keylock to lock single keys irrelevant to a particular function

Various program and situation dependent functions are assigned to function keys. The function name appears above the key in the function bar in the display.

Typical dot-matrix display

Organisation data call-up

Numeric key to input numeric values, multiple programming of numeric keys to type in alphabetic characters.

On/Off

Function change key

Print key

Enter key

Zeroing key

Tare key

Scale change key



Technical data

Housing

- › Stainless steel housing made of chrome nickel steel 1.4301
- › Protection Class IP 67
- › Intrinsic weight: 3.6kg
- › For dimensions see dimensional drawing

Keypad

- › Membrane keyboard with 32 large keys for safer operation
- › Text input using multifunctional keys

Indicator

- › Indicator with dot matrix display with 240 x 128 pixels
- › Settable backlighting

Environmental conditions

- › Temperature range: -10°C to +40°C

Inputs/outputs

- › 8 outputs and 2 inputs, freely assignable, optionally, 8 outputs and 8 inputs, freely assignable

Interfaces

- › 1x RS 232 serial interface (standard)
- › Optionally a second RS 232 or RS 422 interface (2- or 4-wire), 20mA CL
- › RS 485 interface
- › External PC keyboard

Electronic connection

- › Integrated power adapter with extremely wide range of power supply from 100-240V, 50/60Hz, 400mA
- › Power plug with 2m power cord
- › Optionally: DC power supply 12V, 24V or 48V
- › Load cell power supply either 5VDC or 5VAC at 33Hz
- › Minimum input signal 0.25µV/e
- › Measuring cable length max. 80m and 0.14mm

Weighing electronics

- › Connection of 1 to 3 measuring points internally, total of 30 measuring points
- › 4- or 6-wire technology, approvable resolution to 10,000e
- › Internal resolution 10,000,000d
- › Measuring value rate: 67/s
- › Sensitivity 0.25µV/e
- › Resolution: $n \leq 6000e$ (vehicle weighbridge $n \leq 3000e$)

Approval Class III

- › Max. weighing range: 0.1kg to 120t
- › With single-range scales: $n < 10,000e$, with multirange and multidivision scales: $n = 2 \times 6000e$ or $3 \times 3000e$

Memories

- › Approvable data memory (32MB) for memory capacity up to min. 2 million weighing operations (optional)
- › Alibi ID by consecutive number
- › Fixed value memory for total of 400 fixed values valid for all programs and failsafe

Date and time memory

- › Battery backed real-time clock

Use in Ex zones

- › The standard Terminal 3030 may not be used in areas subject to explosion hazards.
- › There is a version available for Ex zones 2 and 22.

Ordering information

| Order Numbers | Description | Dimensions | Weight |
|---------------|-------------------------|-----------------|--------|
| | | mm | kg |
| 3030.01.001 | Bench design | 302 x 218 x 114 | 3,7 |
| 3030.01.002 | Wall or stand supportlg | 302 x 218 x 114 | 3,7 |
| 3030.01.003 | Assembly in switchboard | 302 x 218 x 114 | 3,7 |

Application programs

The Soehnle Professional Program Terminal 3030 is the modern solution for many weighing operations in trade, commerce and industry with its 10 programs.

Weighing and taring

- › Manual tare input
- › Multiplicative tare
- › Provisional tare
- › Automatic tare
- › Up to 400 fixed value tare memory locations

Totalising and batching

- › Totalise gross, tare and net weights in a total memory
- › Automatic totalising
- › Manual inputs and clear function
- › Consecutive number and item counter

Counting

- › Convenient reference weight calculation
- › Reference weight input
- › Reference weight optimisation
- › Piece removal
- › Piece count totalising
- › Quantity check and metering
- › Output signals with start function
- › Reference statistics
- › Reference weight fixed value memory

Checking

- › Weigh-in at a setpoint weight
- › Display of deviation and tolerance by graphic symbols and as weight value
- › Reference sample weigh-in
- › Totalising identical check weighing products
- › Output signals with start function
- › Check fixed value memory

Classifying

- › Dividing weighing products in max. 5 classes
- › Defining the classes by weight input and percentage input (classes 2 to 5)
- › Totalising weighing products allocated to the same class
- › Output signals with start function
- › Classifying fixed value memory

Recipes

- › Multiple processing of recipes
- › Recipe component weigh-in in one container
- › Component check
- › Output signals with start function

Weight conversion

- › Weighing with different physical units, e.g. litre, metre, etc.
- › Convenient input and measurement of specific weight
- › Freely defining physical unit and decimal places
- › Totalising identical units
- › Check and metering function
- › Output signals with start function
- › "Weight conversion" fixed value memory

Vehicle weighbridge

- › Determining the payload by first and second weighing or by weigh once operation
- › Memory for vehicle empty weight
- › Vehicle assignment list with 50 entries
- › Identification by entering the registration number
- › Totalising the payload
- › Calculating a weighing charge
- › Control lights
- › Vehicle check with output signals

Interface programming

- › Controlling 8 outputs and 2 inputs
- › Totalising function
- › Value reaction to scale or total memory
- › Output signals with start function
- › "Interface programming" fixed value memory

Percentage weighing

- › Weight value assigned to a percentage
- › Assigning 1 - 100%
- › Totalising function
- › Check and metering function
- › Output signals with start function

FOR MEASURABLE SUCCESS

SOEHNLE
PROFESSIONAL

Your Soehnle Professional dealer:

www.soehnle-professional.com